

80 Cards From One Simply Scrappin' Kit

Preparation –

- Cut off border strips from sticker portion
- Cut border strips into 4" sections
- Printed cardstock – cut Print A and Print B (3 sheets each) as pictured below. If one print is a stripe, cut 2 vertical and one horizontal.
- Solid cardstock – cut Color A (2 sheets), Color B (2 sheets), Color C (2 sheets) and Color D (2 sheets) as pictured below

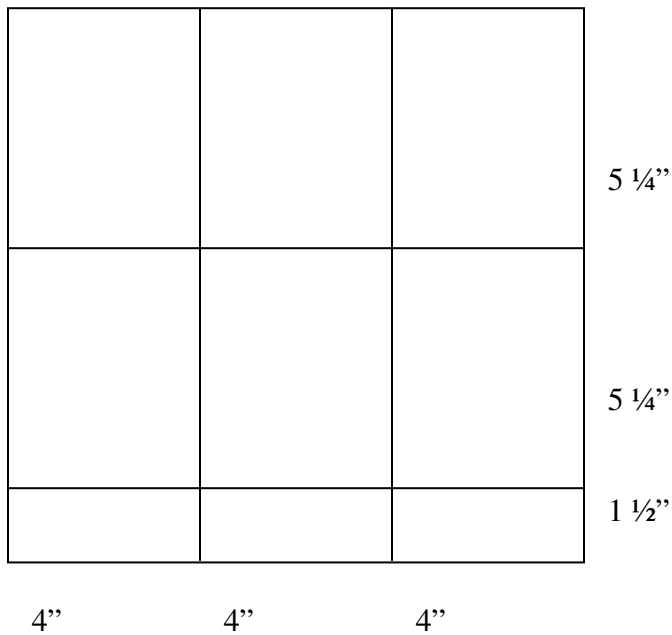

You will end up with 6 pieces of 5 1/4" x 4" and 3 pieces of 1 1/2" x 4" for each sheet.

All card fronts will be mounted on coordinating cardstock to make the final card.

When making cards with a kit for the first time I assembled the paper and border strip portion of all cards first and then added large die cuts and stamped messages just before mounting to the white cardstock. I cut apart the die cuts and laid them out on the cardstock before committing to a final layout.

Directions by Jan Farring. Adapted from Jennifer Trembley, Amanda Cox, and Stephanie Carroll

Border Strip Cards (18 cards)

Materials Needed –

9 – 5 ¼ x 4 color A

6 – 5 ¼ x 4 color B

3 – 5 ¼ x 4 color C

Border Strips

For each of these 18 cards put 2 – 3 border strips on one end of card. Add large diecut stickers or Stamped words.

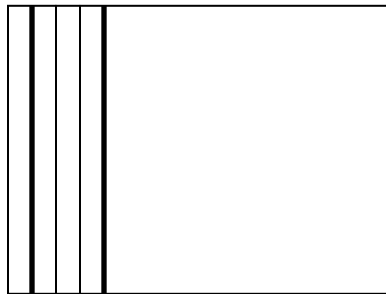
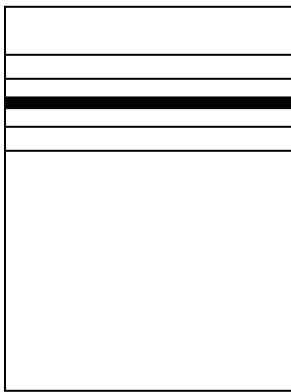

Directions by Jan Farring. Adapted from Jennifer Trembley, Amanda Cox. and Stephanie Carroll

Vertical Strip Cards (14 cards)

Materials Needed

8 – 5 ¼ x 4 print A

6 – 5 ¼ x 4 print B (if you have a stripe you may want the stripe to be vertical)

6 – 1 ½ x 4 color A

4 – 1 ½ x 4 color B

4 – 1 ½ x 4 color C

Optional up to 18 – 7” pieces of ribbon.

Tie ribbon around small strip. Adhere small strip of cardstock to each card front about 1 inch from card top (or bottom).

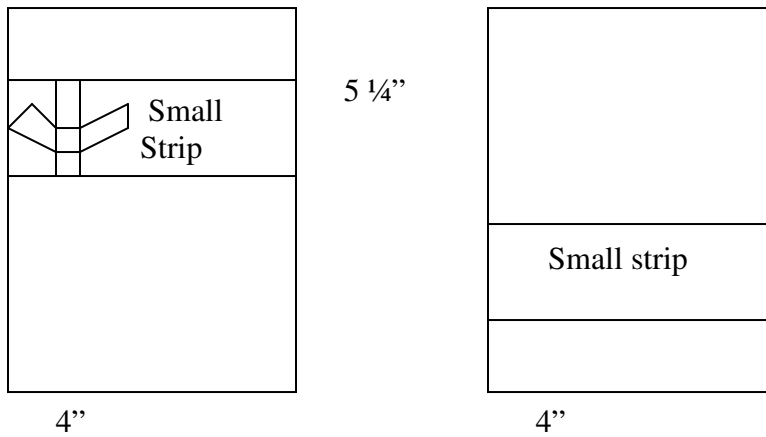

To finish cards stamp a greeting on small strip or place a die cut on strip.

Directions by Jan Farring. Adapted from Jennifer Trembley, Amanda Cox. and Stephanie Carroll

Horizontal Strip Cards (28 cards)

Materials Needed –

2 – 5 ¼ x 4 print A
8 – 5 ¼ x 4 print B
3 – 5 ¼ x 4 color A
6 – 5 ¼ x 4 color B
7 – 5 ¼ x 4 color C
2 – 5 ¼ x 4 color D

9 – 1 ½ x 4 print A
9 – 1 ½ x 4 print B
2 – 1 ½ x 4 color B
2 – 1 ½ x 4 color C
6 – 1 ½ x 4 color D

Option – ribbon or border strips

Adhere small strip to horizontal card so it is flush with the edge. Put print strips on solid cards and solid strips on print cards. Tie ribbon around card front before mounting to cardstock. Center the ribbon down the middle of the small strip. Or place a left over border strip down middle of strip or on the seam between the strip and card front.

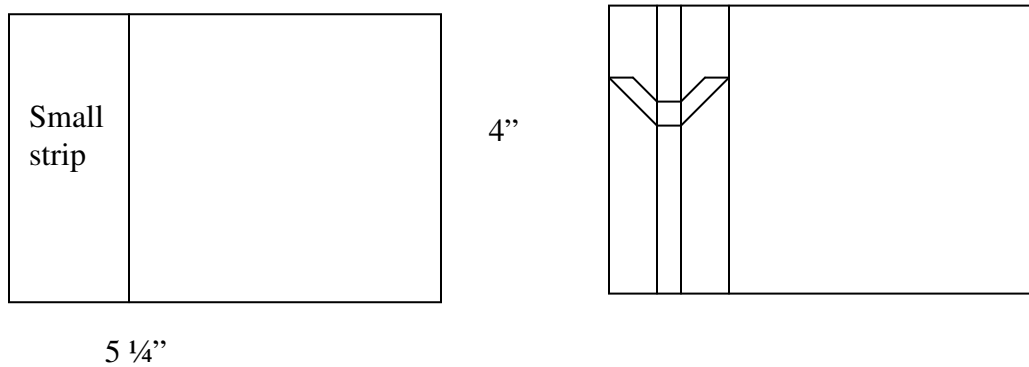

Finish off card with a die cut or stamped image in the large space on the card front.

Directions by Jan Farring. Adapted from Jennifer Trembley, Amanda Cox. and Stephanie Carroll

Split Cards (20 cards)

Materials Needed –

2 – 5 ¼ x 4 print A
8 – 5 ¼ x 4 print B
8 – 5 ¼ x 4 color A
2 – 5 ¼ x 4 color C

Option – ribbon or border strips.

Cut half of the card fronts in half vertically and the other half again in half horizontally. You will now have 20 – 5 ¼” x 2” strips and 20 – 2 5/8” x 2” strips. Mix and match one solid with one print and adhere to base cardstock. I put the print on top and solid on bottom. Cover seam with a border strip or tie ribbon around card front.

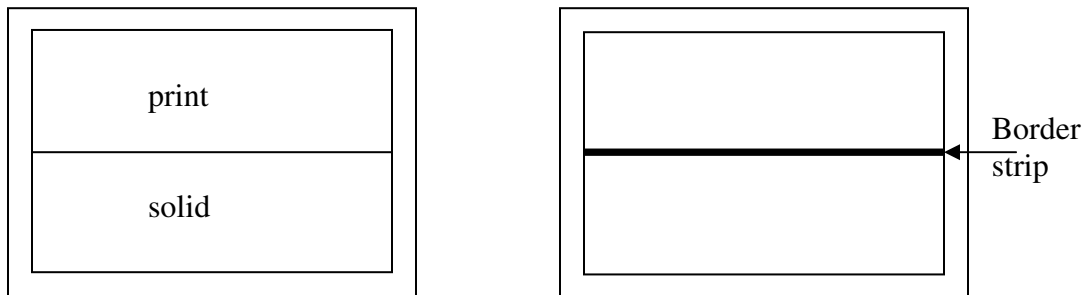

Finish card by putting a small die cut shape(s) at one end of solid strip and stamping a greeting in the remaining area.

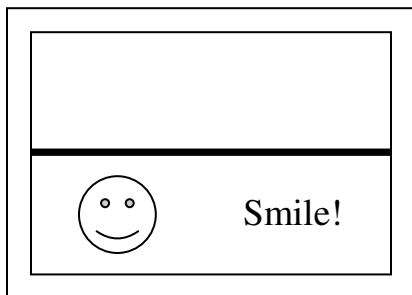

Directions by Jan Farring. Adapted from Jennifer Trembley, Amanda Cox. and Stephanie Carroll